



Thermo Scientific Environmental Chamber

Model 3907 and 3948 Operating Manual

50158234 Rev. E

July, 21st 2020

Visit us online to register your warranty
www.thermoscientific.com/labwarranty

© 2020 Thermo Fisher Scientific Inc. All rights reserved.

Thermo Fisher Scientific Inc. provides this document to its customers with a product purchase to use in the product operation.

This document is copyright protected and any reproduction of the whole or any part of this document is strictly prohibited, except with the written authorization of Thermo Fisher Scientific Inc. The contents of this document are subject to change without notice.

All technical information in this document is for reference purposes only. System configurations and specifications in this document supersede all previous information received by the purchaser. Thermo Fisher Scientific Inc. makes no representations that this document is complete, accurate or error-free and assumes no responsibility and will not be liable for any errors, omissions, damage or loss that might result from any use of this document, even if the information in the document is followed properly.

This document is not part of any sales contract between Thermo Fisher Scientific Inc. and a purchaser. This document shall in no way govern or modify any Terms and Conditions.

Trademarks

Thermo Scientific is a brand owned by Thermo Fisher Scientific, Inc. All other trademarks mentioned in the operating instructions are the exclusive property of the respective manufacturers.

Thermo Fisher Scientific LLC
401 Millcreek Road, Box 649
Marietta, OH 45750
USA

Thermo Fisher Scientific LLC is an affiliate to:
Thermo Fisher Scientific Inc.
81 Wyman Street
Waltham, MA 02454
USA

Table of Contents

Chapter 1 Safety Notes.....	1-1
Explanation of the Safety Information and Symbols	1-1
Additional Symbols for Safety Information.....	1-1
Basic Operating Precautions.....	1-2
Operational Safety Rules	1-3
Warranty	1-4
Intended Use.....	1-4
Unintended Use	1-4
Standards and Directives	1-5
Chapter 2 Delivery of the Environmental Chamber	2-1
Packaging	2-1
Acceptance Inspection	2-1
Scope of Delivery.....	2-2
Chapter 3 Transport Information	3-1
Lifting Model 3907	3-1
Moving Model 3948	3-2
Chapter 4 Installation	4-1
Ambient Conditions.....	4-1
Location Requirements	4-1
Intermediate Storage	4-2
Installing the Wall Anchors	4-2
Power Connection	4-3
Installing the Shelves	4-3
Leveling the Unit.....	4-3
Connect Water Inlet for Humidity System.....	4-3
Alternate Water Supply for Humidity System.....	4-4
Attaching Drain Connections	4-5
Chapter 5 Product Description	5-1
4-20 Milliamp Output	5-2
Remote Alarm Contacts	5-2
IR CO2 Option	5-2
Connect the CO2 Source.....	5-2
Set the CO2 Content.....	5-4
CO2 Control and Indicators	5-4
Set Up the Heatless Dryer (Optional)	5-5
Access Port.....	5-6
Solid Door (optional).....	5-6
Chapter 6 Start-Up	6-1
Set the Overtemp Safety Thermostat.....	6-1
Set the Undertemp Safety Thermostat.....	6-2

Chapter 7 Operation	7-1
Preparing the Environmental Chamber	7-1
Device Check	7-1
Preliminary Cleaning and Disinfecting	7-1
Chapter 8 Handling and Control	8-1
Control Panel.....	8-1
Set the Operating Temperature.....	8-5
Set the Operating Humidity.....	8-5
Air Exchange Ventilator Caps.....	8-6
Set Up the Heatless Dryer (Optional)	8-6
Chapter 9 Cleaning and Disinfection	9-1
Cleaning	9-1
Clean the Glass Doors.....	9-2
Moisture-Sensitive Components	9-3
Cleaning Exterior Surfaces	9-3
Cleaning Operation Panels	9-4
Wipe / Spray Disinfection	9-4
Predisinfection.....	9-4
Cleaning the workspace	9-5
Final Disinfection	9-5
Chapter 10 Maintenance	10-1
Maintaining the Humidity Generator	10-1
Preventive Maintenance for Environmental Chambers	10-2
Returns for Repair	10-4
Chapter 11 Disposal	11-1
Chapter 12 Specifications	12-1
Chapter 13 Service	13-1
Remove Software Lockout.....	13-1
Controller Configuration	13-2
Offset Calibration (Temp/Humidity).....	13-2
Set Door Heater Control	13-3
Clean/Adjust Steam Generator.....	13-4
CO2 Controller Calibration.....	13-5
Change PID Tuning	13-6
Watlow PM Control Auto Tune	13-7
Configuration Record	13-8
Honeywell Truline Configuration Record	13-13
Chapter 14 Information.....	14-1
Contact.....	14-1

Safety Notes

Explanation of the Safety Information and Symbols

Safety notes and symbols used throughout these operating instructions



Indicates a hazardous situation which, if not avoided, will result in death or serious injuries.



Indicates a hazardous situation which, if not avoided, could result in death or serious injuries.



Indicates a situation which, if not avoided, could result in damage to equipment or property.

NOTE

Is used for useful hints and information regarding the application.

Additional Symbols for Safety Information

Important operating and/or maintenance instructions. Read the accompanying text carefully.



Potential electrical hazards. Only qualified persons should perform procedures associated with this symbol.



Equipment being maintained or serviced must be turned off and locked off to prevent possible injury.





WEEE Compliance: Thermo Fisher Scientific has contracted with companies for recycling/disposal in each EU Member State. For further information, send an email to wEEE.recycle@thermofisher.com.

For any activity on the environmental chamber:

- ✓ Always use the proper protective equipment (clothing, gloves, goggles, etc.)
- ✓ Always dissipate extreme cold or heat and wear protective clothing.
- ✓ Always follow good hygiene practices.
- ✓ Each individual is responsible for his or her own safety.

Basic Operating Precautions

These operating instructions describe environmental chambers.

The environmental chambers have been manufactured to the latest state of the art and have been tested thoroughly for flawless functioning prior to shipping. However, the environmental chambers may present potential hazards, particularly if it is operated by inadequately trained personnel or if it is not used in accordance with the intended purpose.

Therefore, the following must be observed for the sake of accident prevention:

- Never step into the unit.
- The environmental chambers must be operated by adequately trained and authorized professional personnel.
- The environmental chambers must not be operated unless these operating instructions have been fully read and understood.
- For any operation of this device, the operator must prepare clear and concise written instructions in the language of the operating and cleaning personnel based on these operating instructions, applicable safety data sheets, plant hygiene guidelines, and technical regulations, in particular:
 - The decontamination measures to be employed for the environmental chamber and the accessories used with it.
 - The safety precautions to be taken when processing specific agents.
 - Wearing protective equipment when handling e.g. microbiological and biological samples.
 - The measures to be taken in case of accidents.
- Repair work on the environmental chamber must be carried out only by trained and authorized expert personnel.

- Disconnect the unit from all power sources before cleaning, troubleshooting, or performing other maintenance on the product or its controls. To disconnect power supply to the environmental chamber, unplug the supply cord at the back of the chamber. Note that deactivating the main switch on the front control panel to the Off position is not sufficient to disconnect power.
- The contents of these operating instructions are subject to change at any time without further notice.
- Keep these operating instructions close to the environmental chamber so that safety instructions and important information are always accessible.



Humidity

After transport and decommissioning, or storage under humid conditions a drying-out process must be performed. During the drying-out process the equipment cannot be assumed to meet all the safety requirements of the IEC 61010-2-010 standard. The drying-out period is 2 hours.

- Should you encounter problems that are not detailed adequately in these operating instructions, please contact Thermo Fisher Scientific immediately for your own.

Operational Safety Rules

The following rules must be heeded when working with environmental chambers:

- Observe the sample weight limits specified for your environmental chambers, whole and its shelving in particular; see “Specifications” on page 12-1.
- Arrange the samples evenly throughout the work space, making sure not to place them too closely to the interior walls to ensure a uniform temperature distribution.
- Do not load your environmental chambers with substances that exceed the capabilities of the available lab apparatus and personal protection equipment to provide sufficient degrees of protection to users and third parties.
- Check the door seal every 12 months for proper sealing performance and possible damage.
- Do not process any samples containing hazardous chemical substances that may be released into the ambient air through defective seals or may cause corrosion or other defects on parts of the environmental chamber.
- The tempering of defined substances or materials with higher moisture content can result in increased condensation in the chamber. Measures must be observed.
- The user is responsible for carrying out appropriate decontamination procedures when hazardous materials are spilled on or inside the environmental chamber.



If the environmental chamber is not used in the manner specified in this operating manual, the protection provided by the equipment design maybe impaired.

Warranty

Thermo Fisher Scientific warrants the operational safety and functions of the environmental chambers only under the condition that:

- The environmental chamber is operated and serviced exclusively in accordance with its intended purpose and as described in these operating instructions.
- The environmental chamber is not modified.
- Only original spare parts and accessories that have been approved by Thermo Scientific are used (third-party spares without Thermo Scientific approval void the limited warranty).
- Inspections and maintenance are performed at the specified intervals.
- An operation verification test is performed after each repair activity.

Intended Use

Thermo Scientific Environmental Chambers are medical devices intended for

- Shelf life studies, packaging testing,
- Stability testing,
- Cultivation of human cells for diagnostics of diseases,
- Cultivation of: cells, tissue, micro organism cultures, insects, plants etc.
- Refrigerated storage or long term storage of cell substances and samples.

The devices employ:

- Precision temperature control - above or below and above ambient temperature, depending on model,
- Precision humidity control: some models only,
- On option: Precision CO₂ control.

Unintended Use

The appliance is not explosion-proof. To avoid the risk of explosion do not load the environmental chamber with tissue, material or liquids that:

- are easily flammable or explosive,
- release vapor or dust that forms combustible or explosive mixtures when exposed to air,
- release poisons,
- release dust,
- exhibit exothermic reactions,

- are pyrotechnical substances,

Refrain also from pouring any liquids onto the internal base plate.

Light option:

Unit is not intended for sample treatment with light

Standards and Directives

- IEC EN 61010-1, IEC EN 61010-2-010
- Low Voltage Directive 2014/35/EU
- EMC Directive 2014/30/EU

Delivery of the Environmental Chamber

Packaging

The environmental chambers are delivered in a rugged packaging box. All packaging materials can be separated and are reusable:

Packaging materials

Packaging carton:	Recycled paper
Foam elements:	Styrofoam (CFC-free and HFC-free)
Pallet:	Chemically untreated wood
Packaging film:	Polyethylene
Packaging ribbons:	Polypropylene

Acceptance Inspection

After the environmental chamber has been delivered, check the delivery immediately for:

- Completeness
- Possible damage

If components are missing or damage is found on the environmental chamber or the packaging, in particular damage caused by humidity and/or water, please notify the carrier as well as Thermo Scientific Technical Support immediately.

Risk of Injury



Should sharp edges have formed in damaged areas or elsewhere on the device, take all necessary precautions to protect personnel handling the environmental chamber. For example, have them wear protective gloves and other personal protection equipment.

Scope of Delivery

Part	Amount
Environmental chamber	1
Shelves and Shelf Channels	
3907	2 and 4
3948	3 and 6
Reflector tester for door switch	1
Set of accessories	1
– Water connection	
– Manual Watlow controller CD	
– Screws for wall mounting	

Transport Information

Lifting Model 3907

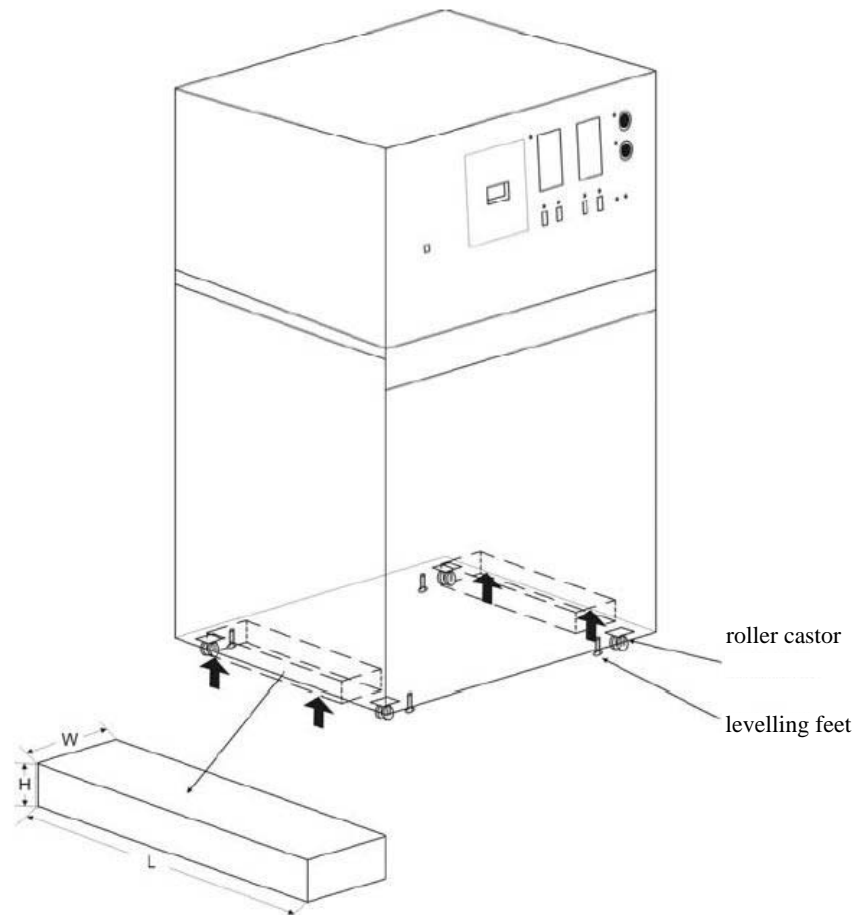

Figure 3-1 Lifting the model



The Model 3907 has a total weight of approx. 261 kg /575 lbs.

Lift the unit only with appropriate lifting gear at the indicated lifting points.

Use 2 wooden blocks (WxLxH / 2 in x 20 in x 1.2 in / 50 mm x 500 mm x 30 mm) under the left and right side between the roller castors as a load spreading block, to avoid damaging the unit.

Levelling feet can be used to lock into position and/or levelling the unit.

Do not stack units!

Moving Model 3948



The Model 3948 has a total weight of approx. 347 kg / 765 lbs

After unpacking and bringing in upright position, the unit is designed to be moved on even surfaces, in a laboratory, to its operating position, only.

Levelling feet can be used to lock into position and/or levelling the unit.

Installation

Ambient Conditions

Location Requirements

The environmental chamber must only be operated in a location that meets all of the ambient condition requirements listed below:

- Installation location indoors in dry areas free from drafts.
- The dust pollution may not exceed the contamination category 2 based on EN 61010-1. Using the environmental chamber in an atmosphere with electrically conductive dust is prohibited.
- The room must be equipped with appropriate ventilation. Solid, level, fire-proof surface; no flammable materials opposite to the rear panel of the environmental chamber.
- The electrical circuitry of the environmental chamber has been designed for an operating height of up to 2000 m above sea level.
- If a high-voltage test is to be performed on the unit, it must first be heated for around 30 minutes at 50°C.
- The ambient temperature must be within 16 °C - 32 °C (61 °F to 90 °F).
- Devices that produce excessive amounts of heat must not be placed near the environmental chamber.
- Power line voltage variations must not exceed $\pm 10\%$ of the nominal voltage.
- Transient surges must lie within the range of levels that normally occur in the power supply system. The impulse withstand voltage based on surge category II of IEC 60364-4-443 shall be applied at the nominal voltage level.
- Relative humidity up to 80%, non condensing, at an ambient temperature of 31°C, decreasing linearly to 50% at 40 °C non condensing.
- Please note: Should condensation exist, wait until the moisture has evaporated completely before connecting the environmental chamber to a power source and powering up.



WARNING

Connect to suitable power supply only.

See chapter Technical Specifications for specific power input for the respective unit.

Intermediate Storage

When the chamber is placed in intermediate storage, which is permissible for a maximum of four weeks, make sure that the ambient temperature is between 20°C to 60°C (68°F to 140°F) and the maximum relative humidity does not exceed 90%, non-condensing.

Installing the Wall Anchors

The unit has two wall anchor studs located in the left and right side of the cabinet. Use the provided 5/16" bolts to secure the wall anchors to each side of the cabinet top. Anchors that connect between the cabinet sides to facility wall are customer supplied.



To prevent tipping, install the wall anchors and secure the unit before using.

NOTE

For Model 3948 - Wall anchors are required to meet the UL Tip Test Safety Standards. For Model 3907 - Wall anchors are not required to meet the UL Tip Test Safety Standards. However, they are included in the event that the cabinet is installed on a benchtop.

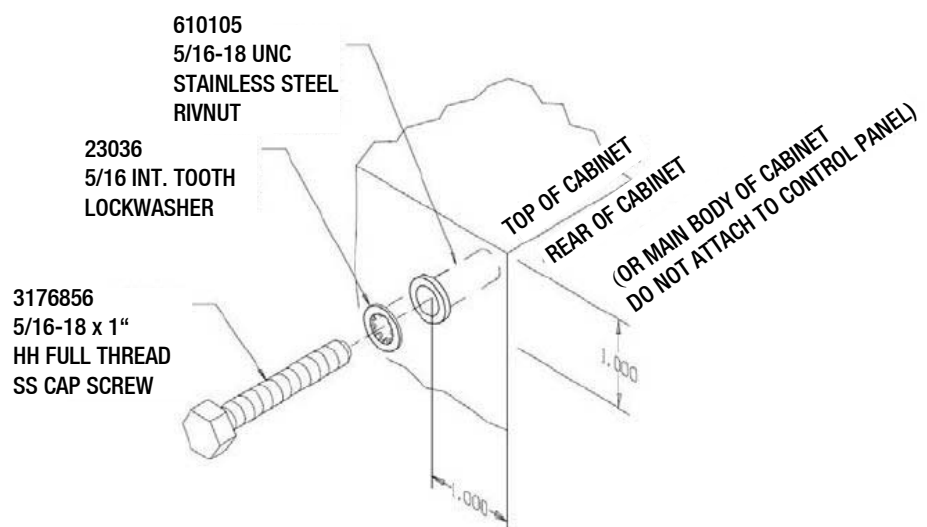

Figure 4-1 Wall Anchor Installation

Power Connection

See the serial tag on the side of the unit or the “Specifications” section for electrical specifications.



Connect the environmental chamber to a grounded, dedicated circuit. For Models 3907 and 3948, the power cord connector is the mains disconnect device. Position the chamber to allow unobstructed access so the unit can be easily disconnected in an emergency.

For Models 3907 and 3948, plug the provided 10 ft. power cord with the CEE 7/7 plug into the grounded dedicated electrical circuit.

Installing the Shelves

The shelves may be installed at any level in the environmental chamber. Install a shelf channel on each side. With the tabs pointing up, attach the channel by locating the rivet into a slotted hole, far end first. Pull the channel toward the front and slide the front rivet on the channel into the slotted hole and press down. Make sure that the channels are opposite each other so that the installed shelf will be level.

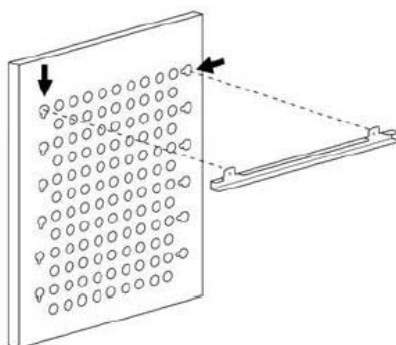

Figure 4-2 Install Shelf Channel

Leveling the Unit

Place a bubble-type level on a shelf inside the environmental chamber. Adjust the feet as needed; counterclockwise to lengthen or clockwise to shorten. Level the unit front-to-back and left-to-right.

Connect Water Inlet for Humidity System

The humidity reservoir will require approximately three cups (0.710 liter) of water on the initial filling. For best operation of the environmental chamber, sterilized distilled, demineralized or de-ionized water should be used in the humidity reservoir. Water purity should be in the resistance range of 50K to 1M Ω *cm, or a conductivity range of 20.0 to 1.0 μ S/cm. Refer to ASTM Standard D5391-93 or D4195-88 for measuring water purity.

Distillation systems, as well as some types of reverse osmosis water purity systems, can produce water in the quality range specified. Tap water is not recommended as it may contain chlorine, which can deteriorate the stainless steel. Tap water may also have a high mineral content, which would produce a build-up of scale in the reservoir. High purity or ultrapure water is not recommended as it is an extremely aggressive solvent and will deteriorate the stainless steel. High purity water has a resistance of above 1M to 18M Ohm*cm. Even high purity water can contain bacteria and organic contaminants. Water should always be sterilized or treated with a decontaminant, safe for use with stainless steel as well as safe for the product, prior to being introduced into the humidity reservoir.

NOTE

Thermo Fisher Scientific offers free water sample testing. For further information contact our Customer Service Department.



Distilled or de-ionized water used in humidity reservoir must be within a water quality resistance range of 50K to 1M Ohm*cm to protect and prolong the life of the stainless steel. Use of water outside the specified range will decrease the operating life of the unit and may void warranty.

The water inlet is the 1/8" FPT connection located on the rear top center of the environmental chamber. For pressurized systems, water inlet pressure must not exceed 40 PSI. A manual shut-off valve should be installed between the main water supply and the environmental chamber. A water strainer is provided that can be connected to the back of the cabinet if desired.



To prevent mineral buildup on humidity generator walls, it may be necessary to clean the humidity generator with a non-metallic abrasive pad and flush thoroughly every two to three months. Refer to "Clean/Adjust Steam Generator" on page 13-4 .

Alternate Water Supply for Humidity System

If an in-house water supply of the required purity range (50K to 1M Ohm*cm) is not available, an alternate water supply method can be used. A large vented carboy (5 gal. minimum) of water in the required purity range can be placed on top of the unit. The provided 1/4" hose barb fitting should be used to connect to the 1/8" FPT water inlet fitting, located on the rear top center of the environmental chamber.

NOTE

To prevent accidental slip off of the connecting hose and flooding of the floor, use of carboy with barbed fitting only.

NOTE

The maximum water consumption of this environmental chamber could be as high as 2 gallons per day. When using an alternate water supply method, it is recommended that the supply be checked periodically based on source volume.

Attaching Drain Connections

The cabinet's 3/8" MPT drain connection is located on the rear (lower left side) of the cabinet (Figure 4-3). A P-trap is included with the unit and must be installed on the connection.

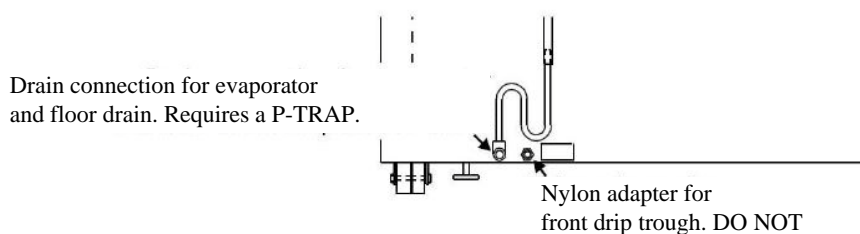

Figure 4-3 P-Trap Installation Location

To install the drain connection:

1. Using teflon pipe thread tape, tape the threads on the cabinet drain connection.
2. Using an open end adjustable wrench, install the P-trap onto the connection. Make sure the trap section is positioned down.
3. Push a piece of 3/8" ID tubing onto the trap and direct the tubing to a convenient drain. Install a hose clamp on the tubing, if desired. A condensate evaporator (P/N 1900031) or condensate pump (P/N 184062) may also be used.

To connect the nylon adapter from the front drip trough, do not install a p-trap on the nylon adapter (Figure 4-3). Push a piece of 3/8" ID tubing onto the nylon adapter and direct the tubing to a convenient drain. Install a hose clamp on the tubing, if desired.

Product Description

There are 2 types of environmental chambers:



Figure 5-1 Front view

Type	Dimension	Power supply	Refrigerant	Process
3907	311 Liter /11 cu.ft.	230 V–50/60 Hz	R513a	with Temperature & Humidity Control
3948	821 Liter / 29 cu.ft.	230 V–50/60 Hz	R513a	with Temperature & Humidity Control



This devices comply with EU-F-Gas Regulation No. 517/2014 and contain fluorinated greenhouse gases in a hermetically sealed system. If a leak in the sealed system is detected, the operator shall repair without undue delay.

4-20 Milliamp Output

The environmental chamber is equipped with 4-20mA output for the remote transmission of temperature, humidity and CO₂ data. A terminal strip is located on the back of the environmental chamber for convenience. Refer to Figure 5-2 for terminal pin identification.

1	2	3	4	5	6	7	8	9	10
+	-	+	-	Common	N.O.	N.C.	+	-	
4-20		4-20		Common			4-20		4-20
Temperature 4-20mA (-20 to 80°C)		Humidity 4-20mA (0 to 100%)		Remote Alarm 30V 1A max.			CO ₂ 4-20mA (0 to 20%)		

Figure 5-2 Terminal Pin Identification

Remote Alarm Contacts

Remote alarm connections are also included on the terminal strip providing Normally Open (N.O.) and Normally Closed (N.C.) contacts. C is the Common terminal. The remote alarm will activate when either the chamber's temperature, humidity, or CO₂ go out of the set alarm limits.

NOTE

When the chamber temperature control setpoint is changed, the undertemp safety thermostat must be reset to accommodate the change.

NOTE

The undertemp control is not directly calibrated. The numbers on the dial are for reference only.

IR CO₂ Option

This section applies to units with the IR CO₂ option only.

Connect the CO₂ Source

For the most economical use, the liquid CO₂ supply tanks should be without siphon tubes, so that only CO₂ gas enters the environmental chamber injection system. Two tanks may be joined together with a manifold to ensure a continuous CO₂ supply.

Install a two-stage pressure regulator, with indicating gauges, at the supply cylinder outlet. The high-pressure gauge should have an indicating range of 0 to 2000 psig to monitor tank pressure. The low-pressure gauge should have an indicating range of 0 to 30 psig to monitor input pressure to the chamber injection system. A suitable two-stage pressure regulator is available.

The CO₂ source must be regulated at a pressure level of 15, ±5 psig. Higher pressure levels may damage the CO₂ control system. The user should determine the most economical pressure level, between 10 psig and 20 psig appropriate for the desired CO₂ percentage in the chamber. Use only sufficient pressure to maintain recovery time after door openings.

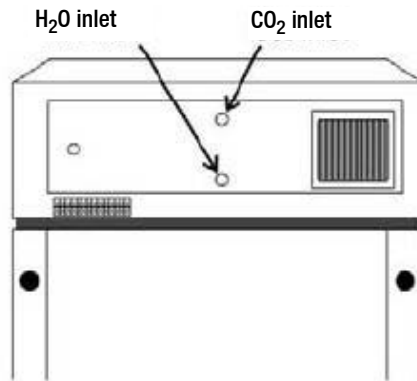

Figure 5-3 Inlet Connections

To connect the CO₂ supply (Figure 5-3):

1. Connect the CO₂ tubing to the ¼" hose fitting installed in the CO₂ inlet.
2. Check the tubing connection for leaks.



Do not leave unit door open when using CO₂.



Raised levels of CO₂ can lead to asphyxiation, only use in well ventilated rooms.



If CO₂ inlet pressure level is higher than 15 ±5psig, liquid CO₂ might enter the unit and damage the CO₂ control system, valves, tubing and filters.



Only connect CO₂ sources to the CO₂ inlet. Connecting sources of other gases than CO₂ might damage the unit.

Set the CO₂ Content

The Watlow CO₂ controller's upper display shows the actual CO₂ content inside the chamber. The lower display shows the CO₂ setpoint.

To set the CO₂ content (0% to 20%), press the Up or Down arrow keys on the Watlow PM6 Controller.

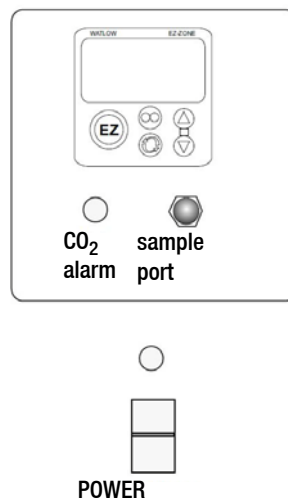

Figure 5-4 Watlow PM6 Control

CO₂ Control and Indicators

Sample Port - The sample port is used for checking CO₂ percentage in the environmental chamber by an independent test instrument (such as with a Fyrite, or similar CO₂ test instrument).



To prevent CO₂ loss, the sample port must be capped when it is not in use.

CO₂ Alarm - The CO₂ alarm is factory set to activate when the chamber CO₂ content deviates from configured alarm set points (see "Configuration Record" on page 13-8). When a CO₂ alarm occurs, the CO₂ Alarm indicator on the control panel lights and the audible alarm sounds.

The CO₂ alarm high and low setpoints are established through the Watlow PM6 CO₂ controller (A.LO and A.HI). Refer to the "Configuration Record" on page 13-8.

Set Up the Heatless Dryer (Optional)

The Heatless Drier is a factory installed option. If your unit includes this option, the oil removal filter will need to be installed. The filter is shipped in a separate box, wrapped in bubble wrap with the manual.

1. The heatless drier requires an air supply of 90 psi capable of 10 cfm, at minimum. It is recommended that the air supply is greater than the minimum required by the drier.
2. Install the required oil removal filter between the customer air supply and the connection to the heatless drier assembly. Refer to Figure 5-5.

NOTE

Cabinets with factory installed heatless driers are tested and calibrated at 30°C/30% RH. It is recommended that cabinets are re-calibrated when set parameters are changed to another temperature and/or humidity set point.

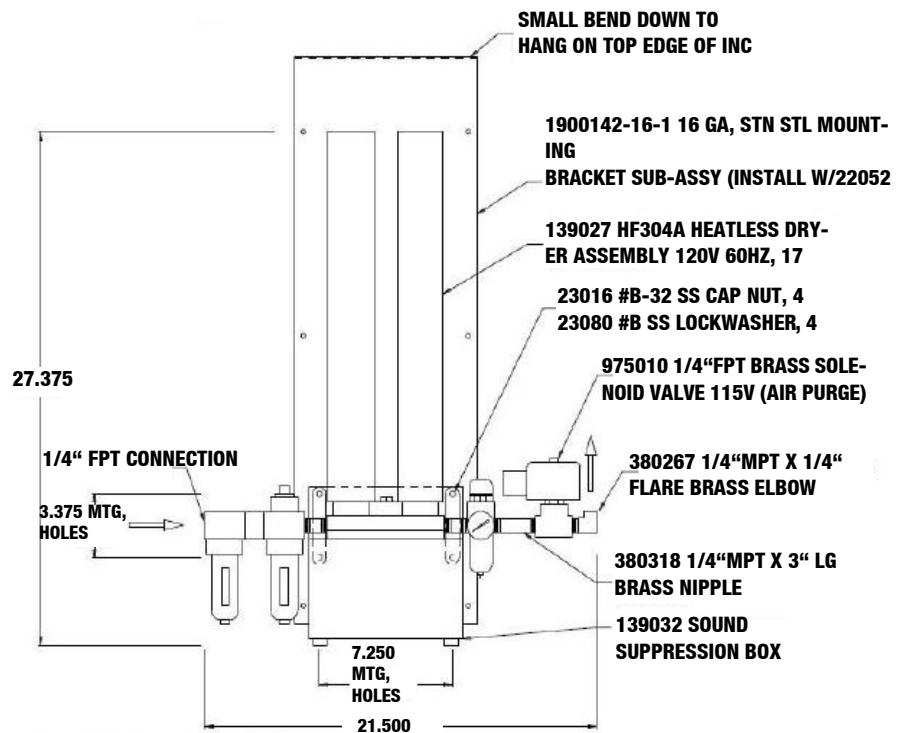

Figure 5-5 Heatless Dryer Assembly

Access Port

At the left side of the unit is one access port to feed-in cables to the inner chamber. To minimize the opening cone shaped inserts are available. If not in use, the inside and outside openings should be closed using the 2 plugs supplied with the unit.



Figure 5-6 Access Ports

Solid Door (optional)

The solid door replaces the standard glass door. It has a heater built in to reduce condensation.



Figure 5-7 Solid door with inner glass door 3907



Figure 5-8 Solid door with inner glass door 3948



Figure 5-9 Solid door drain

The drains for condensed water are in the solid door and the front frame.



Figure 5-10 Solid door drain

The condensed water is drained off to the rear side.



Door opening/closing

To avoid sample damage by vibration, do not roughly open or close the glass and solid door.

To avoid slipping due to a water puddle in front of the unit caused by condensed water dropped down on the door, do not roughly open or close the solid door.



If water leaks the unit, clean up the water immediately to avoid slipping.

Check for the cause of the leakage and eliminate before continuing operation.



Pinch of body parts

To avoid pinching of fingers or hand, e.g. on hinge side between door and top box, close the solid door only with the handle.

Start-Up

When the humidification system is operational, the environmental chamber may be started. Preset the controls as follows:

Parameter	Unit
Overtemp Safety Thermostat	Fully Clockwise
Undertemp Safety Thermostat	Fully Counterclockwise
Main Power Switch	ON
Humidity Controller	Desired Setpoint
Temperature Controller	Desired Setpoint
Door Heater	40% (factory set)

NOTE

- When operating the environmental chamber with a light module, always switch on the cooling
- Observe temperature display on the device

Set the Overtemp Safety Thermostat

For best overall performance of the environmental chamber, the refrigeration switch should be turned On for most applications. When running Low or No humidity at high temperatures, the refrigeration switch may be turned Off.



The defrost switch must be set to “Auto” when the temperature setpoint is 10°C or below.

Allow the chamber temperature and humidity to stabilize, then set the overtemp safety thermostat as follows:

1. Turn the overtemp control knob slowly counterclockwise until the audible alarm sounds and the overtemp indicator lights.

2. Turn the overtemp control knob clockwise at least 2°. The alarm should be silenced and the overtemp indicator light should go out. The overtemp safety thermostat is now set a few degrees above the control temperature setpoint. When the chamber temperature rises to the overtemp control point, the alarm system will activate, power to the heaters will shut off, and the chamber temperature will be maintained at the overtemp control point.

NOTE

When an overtemp condition occurs, the cause must be determined and corrected before normal operation under the main temperature controller can be resumed.

NOTE

When the chamber temperature control setpoint is changed, the overtemp safety thermostat must be reset to accommodate the change.

NOTE

The overtemp control is not directly calibrated. The numbers on the dial are for reference only.

Set the Undertemp Safety Thermostat

Allow the chamber temperature and humidity to stabilize, then set the undertemp safety thermostat as follows:

1. Turn the undertemp control knob slowly clockwise until the audible alarm sounds and the undertemp indicator lights.
2. Turn the undertemp control knob counterclockwise at least 2° on the scale. The alarm will silence and the undertemp indicator light goes out.

The undertemp safety thermostat is now set a few degrees below the control temperature setpoint. When the chamber temperature drops to the undertemp control point, the alarm system activates, power to the compressor shuts off and the chamber temperature is maintained at the undertemp control point.

When an undertemp condition occurs, the cause must be determined and corrected before normal operation under the main temperature controller can be resumed.

Operation

Preparing the Environmental Chamber

The environmental chamber must not be released for operation before all major start-up activities have been completed (see “Installation” on page 4-1).

Device Check

Prior to starting operation, the following environmental chamber components must be checked for their correct function:

- The door seal in the front frame and solid door must not be damaged.
- The glass door must not be damaged.
- The shelving components must be installed safely.
- Unused sockets of the light modules must be covered with a plug.

Preliminary Cleaning and Disinfecting

Disinfect all interior surfaces with a general-use laboratory disinfectant, such as quaternary ammonium. Rinse thoroughly with sterile distilled water, then 70% alcohol. Dry with a clean cloth as needed.

Disinfect the shelf channels and shelves, then rinse with distilled water before installing.



Before using any cleaning or decontamination method except those recommended by the manufacturer, users should check with the manufacturer that the proposed method will not damage the equipment.

Handling and Control

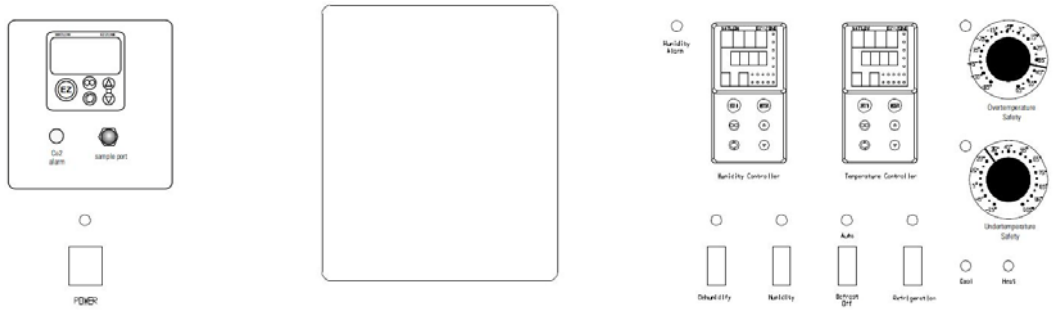

Figure 8-1 Control Panel

Control Panel

Main Power Switch and Indicator Light

The main power switch controls power to the environmental chamber. The main power indicator lights when the power switch is on and the unit is receiving power.

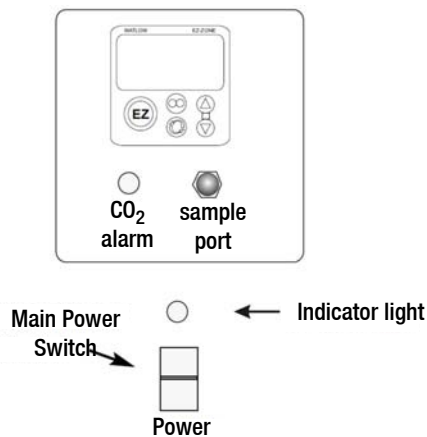

Figure 8-2 Main Power

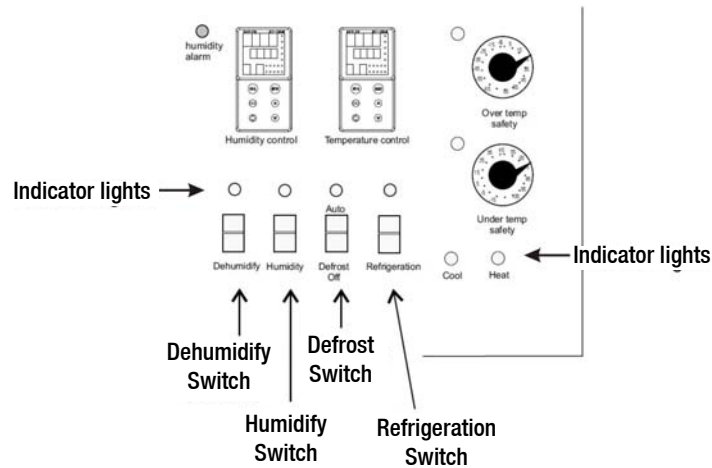

Figure 8-3 Switches

Switch and Indicator Light (Figure 8-3).

The refrigeration switch controls power to the refrigeration system. The refrigeration indicator lights when the refrigeration switch is on and the compressor is receiving power.

Defrost Switch and Indicator Light (Figure 8-3).

The defrost switch controls power to the defrost system. Setting the defrost switch to Auto will provide two 15-minute defrost cycles during a twenty-four hour period. The defrost indicator lights when the defrost switch is on and the environmental chamber is in a defrost cycle.



The defrost switch must be set to Auto when the temperature setpoint is 10°C, or below.

NOTE

When set temperature is above 10°C and the defrost switch is set to Auto, periodic temperature inconsistencies can occur.

Humidity Switch and Indicator (Figure 8-3)

The humidity switch controls the power to the humidification system circuit. The humidity indicator light will cycle as the controller toggles between humidify and dehumidify.

Dehumidify Switch and Indicator (Figure 8-3)

The dehumidify switch is used with the optional heatless dryer P/N 1900139 to provide dehumidification. The heatless dryer injects dry air into the environmental chamber as needed, to maintain humidity levels. When controlling humidity, the dehumidification switch should be in the ON position for most applications. The dehumidification light will cycle on and off as the humidity controller toggles between humidify and dehumidify.

The time switch controls the LED light tubes of the light modules.

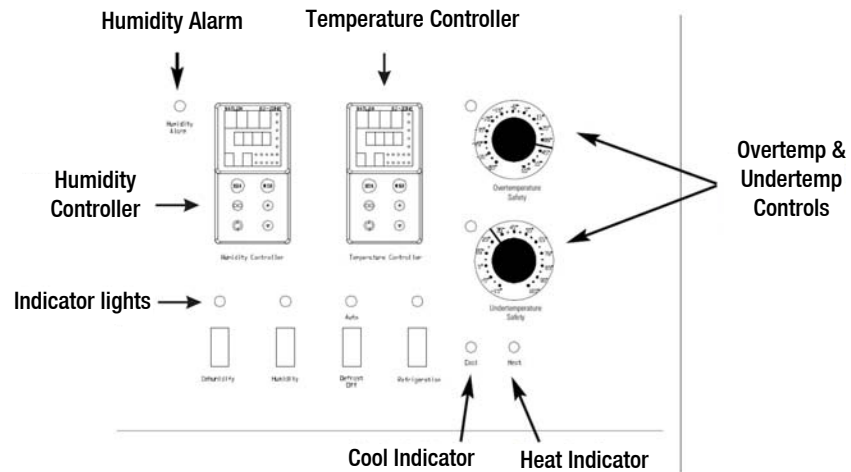

Figure 8-4 Indicator Lights and Controls

Heat Indicator (Figure 8-4)

The Heat Indicator illuminates when the heater activates.

Cool Indicator (Figure 8-4)

The Cool Indicator illuminates when the refrigeration system activates.

Overtemp Safety Control, Indicator Light & Audible Alarm (Figure 8-4)

The overtemp safety thermostat should be set slightly above the operating temperature of the environmental chamber. In the event of an overtemp condition, the overtemp safety thermostat:

- Activate the audible alarm and the overtemp indicator light.
- Interrupts power to the heaters and maintain the environmental chamber's cabinet temperature at the overtemp safety control point.

NOTE

The overtemp control is not directly calibrated. The numbers on the dial are for reference only.

If an overtemp condition occurs, the alarm can only be silenced by raising the overtemp safety thermostat setting. However, the cause of the problem must be determined and corrected before normal operation under the main temperature controller is resumed.

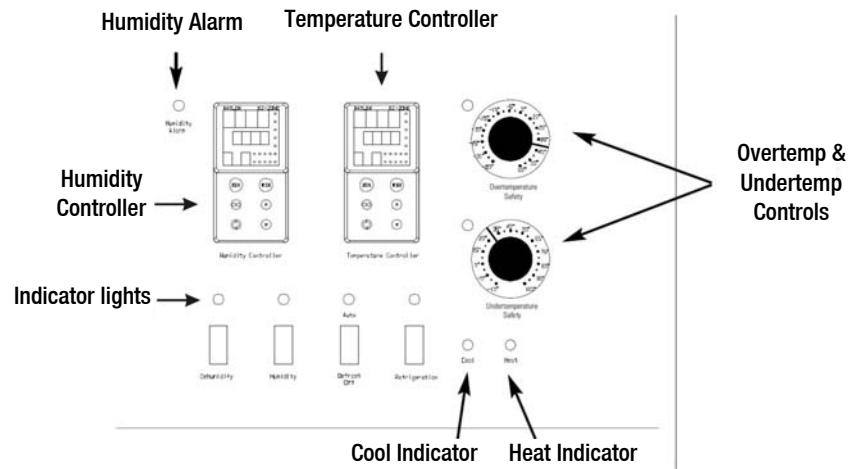

Figure 8-5 Indicators and Controls

Undertemp Safety Control, Indicator Light and Audible Alarm (Figure 8-5)

The undertemp safety thermostat should be set slightly lower than the operating temperature of the environmental chamber. In the event of an undertemp condition, the undertemp safety thermostat will:

- Activate the audible alarm and the overtemp indicator light.
- Interrupt power to the refrigeration system and maintain the environmental chamber’s cabinet temperature at the undertemp safety control point.

NOTE

The undertemp control is not directly calibrated. The numbers on the dial are for reference only.

If an undertemp condition occurs, the alarm can only be silenced by lowering the undertemp safety thermostat setting. However, the cause of the problem must be determined and corrected before normal operation under the main temperature controller is resumed.

Audible Humidity Alarm and Indicator Display (Figure 8-5).

The humidity alarm is a function of the humidity controller (Figure 8-5). When the cabinet humidity goes outside the set parameters of the controller, the #4 indicator on the controller lights, the audible alarm sounds and the humidity alarm indicator on the control panel lights. The alarm can be silenced by pressing either EZ key.

NOTE

The humidity controller's high and low limits are factory-set at 100% and 0%. Therefore, the system will go into the alarm state when the humidity exceeds these percentages by one percent. When operating the environmental chamber near these high or low humidity levels, frequent alarms may occur. This will require that the controller's high or low limit be reset to three or four percent over the high limit or three or four percent under the low limit. Refer to the Watlow User's guide provided. Refer also to "Configuration Record" on page 13-8.

Set the Operating Temperature

The Watlow temperature controller's upper numerical display shows the actual temperature inside the environmental chamber. The lower display shows the temperature setpoint.

To change the setpoint, press the Up or Down Arrows. Temperature is set in one °C/°F increments.

Set the Operating Humidity

The Watlow humidity controller's upper numerical display shows the actual humidity inside the environmental chamber. The lower display shows the humidity setpoint.

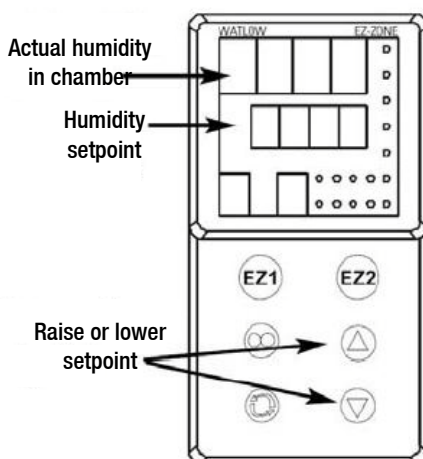

Figure 8-6 Changing Humidity

To change the setpoint, press the Up or Down Arrows. Humidity is set in one percent increments.

Air Exchange Ventilator Caps

Air exchange for the environmental chamber is regulated through the manually adjustable intake and exhaust ventilator caps located on the top of the cabinet. When viewed from the front of the environmental chamber, the intake cap is on the left and the exhaust cap is on the right. The ventilator caps may be opened by turning counterclockwise, and closed by turning clockwise.

For optimum performance of the unit, the vent caps should be closed at all times.

It might be advisable to open the ventilator caps for specific applications, e.g. for increased air exchange in insect hatching.

Set Up the Heatless Dryer (Optional)

The optional heatless dryer (P/N 1900139) provides dehumidification for the environmental chamber (oil removal filter must be installed and an air supply connected - Chapter 5). The dehumidify switch must be turned On for the dryer to operate. The dryer is controlled with the humidity controller and will purge dry air into the chamber as needed to maintain the control set point.

NOTE

Cabinets with factory installed heatless dryers are tested and calibrated at 30°C/30% RH. It is recommended that cabinets are recalibrated when set parameters are changed to another temperature and/or humidity set point.

Cleaning and Disinfection



If the unit has been in service, disconnect the power cord from both the unit and the power source. Allow the unit to cool before proceeding with any maintenance.



Before using any cleaning or decontamination method except those recommended by the manufacturer, users should check with the manufacturer that the proposed method would not damage equipment.



It is the responsibility of the user to immediately clean up after all accidental spills of hazardous materials. Be certain to follow local EHS policies (Environment, Health and Safety) with regards to personal protective equipment, cleaning, and disposal.

Cleaning

The chamber interior may be cleaned with a general-use laboratory disinfectant, such as quaternary ammonium, or alcohol.

The cabinet exterior may be cleaned with soap and water or any nonabrasive commercial glass cleaner. The Thermopane glass door may be cleaned with commercial glass cleaner or with a solution of ammonia and water.



Alcohol, even a 70% solution, is volatile and flammable. Use it only in a well ventilated area that is free from open flame. If any component is cleaned with alcohol, do not expose the component to open flame or other possible hazards.



Do not use strong alkaline or caustic agents. Stainless steel is corrosion resistant, not corrosion proof. Do not use solutions of sodium hypochlorite (bleach) as they may cause pitting and rust.

Clean the Glass Doors

Some precautions in the cleaning and care of the environmental chamber glass doors: Moisture leaches alkaline materials (sodium, Na) from the surface of the glass. Evaporation of the moisture concentrates the alkaline and may produce a white staining or clouding of the glass surface. Cleaning chemicals with a pH above 9 accelerate the corrosion process. Therefore, it is very important to rinse and dry the glass doors after cleaning.



There is no simple method for repairing corroded glass. In most cases, the glass must be replaced.



Electrical shock

Contact with current-carrying components may cause a lethal electric shock.

Prior to cleaning and disinfection work, disconnect the device from the power supply!

- Turn the device off using the power switch.
- Unplug the power connector and protect it against accidental reconnection.
- Make sure the device is de-energized.



Health hazard

The surfaces of the workspace may be contaminated. Contact with contaminated cleaning liquids may cause infections. Disinfectants may contain harmful substances.

When cleaning and disinfecting, always observe the safety instructions and hygiene regulations!

- Wear safety gloves.
- Wear safety goggles.
- Wear mouth and respiratory system protection gear to protect your mucous membranes.

- Observe the safety instructions of the disinfectant's manufacturer and the hygiene supervisor.



Incompatible cleaners

Some device components are made of plastic. Solvents can dissolve plastics. Strong acids or caustic solutions can cause plastic to become brittle. For cleaning plastic components and surfaces, do not use solvents that contain hydrocarbons, solvents with an alcohol content of more than 10% or strong acids or caustic solutions!



Decontamination or cleaning agents

The "Thermo Scientific" company or their agent is to be consulted if there is any doubt about the compatibility of decontamination or cleaning agents.

Moisture-Sensitive Components

Sensitive components

Do not spray cleaning agent onto the controllers of the device. When wiping the device clean, always make sure that moisture does not enter into these components.

Cleaning Exterior Surfaces

1. Thoroughly remove dirt residues and deposits using a solution of tepid water and dishwashing agent.
2. Wipe the surfaces clean using a clean cloth and clear water.
3. Then, wipe the surfaces dry using a clean cloth.

Cleaning Operation Panels

The operation panels are moisture-sensitive.

Do not spray or wipe with cleaner.

Clean using a dry cloth of 100% micro fibre.

Wipe / Spray Disinfection

The manual wipe/spray disinfection is carried out in three stages:

- Predisinfection
- Cleaning
- Final disinfection



Alcoholic disinfectants

Disinfectants having an alcohol content of more than 10% may form, in combination with air, easily combustible and explosive gas mixtures.

When using such disinfectants, avoid open flames or exposure to excessive heat during the entire disinfection process!

- Use such disinfectants only in adequately ventilated rooms.
- After the disinfectant has been allowed to react, wipe the cleaned device components thoroughly dry.
- Observe safety regulations to avoid fire and explosion hazard caused by alcohol-containing disinfectants.



Chloride-containing disinfectants

Do not use chloride-containing disinfectants.

Predisinfection

Remove all samples from the work space and store them in a safe place.

Spray disinfectant onto the surfaces of the work space and of the accessories or wipe the surfaces clean using disinfectant.



Risk of injury by removing the glass panel

The glass panel may only be removed by properly trained and authorized personnel. The glass panel must be held by two persons.

Allow time for disinfectant to act as specified by the manufacturer.

NOTE

Disinfecting hard-to-reach components

Spray hard-to-reach components with disinfectant!

Cleaning the workspace

Thoroughly remove dirt residues and deposits using a solution of tepid water and dishwashing agent.

Wipe the surfaces clean using a clean cloth and plenty of clear water.

Remove the cleaning liquid and wipe all surfaces of the workspace thoroughly dry.

Final Disinfection

Spray the surfaces of the workspace, the shelving system and the parts removed with disinfectant one more time and wipe dry.

Allow the disinfectant to act as specified by the manufacturer.

Reinstall the shelf system and the removed components.

Maintenance



De-energize all potential sources of energy to this unit and lockout/tagout their controls. (O.S.H.A. Regulation, Section 1910-147.)

The continued cleanliness of the stainless steel used in this unit has a direct effect on the appearance and operation of the unit. Use the mildest cleaning procedure that will do the job effectively. Clean the outside of the environmental chamber with soap and water or with any non-abrasive commercial spray cleaner. Clean the inside of the chamber with alcohol and/or soap and water. Disinfect the interior panels with a general use laboratory disinfectant, diluted according to the manufacturer's instructions. Rinse the surface thoroughly after each cleaning and wipe the surfaces dry. Always rub in the direction of the finish polish lines.



Do not use chlorinated solvents on stainless steel as they can cause rusting and pitting.



Do not use volatile or aromatic solvents for cleaning inside the cabinet as their residue can contaminate the cabinet environment.

The Thermopane glass door may be cleaned with commercial glass cleaner or with a solution of ammonia and water.

Maintaining the Humidity Generator

Depending on the quality of water used in the humidification system, it may be necessary to clean the humidity generator every 2 to 3 months. Refer to Chapter 9 for cleaning instructions.

Preventive Maintenance for Environmental Chambers

Your equipment has been thoroughly tested and calibrated before shipment. Regular preventive maintenance is important to keep your unit functioning properly. The operator should perform routine cleaning and maintenance on a regular basis. For maximum performance and efficiency, it is recommended that the unit be checked and calibrated periodically by a qualified service technician. We have qualified service technicians, using NIST traceable instruments, available in many areas. For more information on Preventive Maintenance or Extended Warranties, contact Technical Services.

The following is a condensed list of preventive maintenance requirements. See the specified section of the instruction manual for further details. Cleaning and calibration adjustment intervals are dependent upon use, environmental conditions and accuracy required.

See Manual Section	Action	3 Months	Yearly	2 Years	5 Years	6 Years
--	Inspect door latch, hinges and door gasket seal.		✓			
8	Check air exchange ventilator caps for adjustment; open or close as required.		✓			
9	Perform a complete decontamination procedure. Wipe down interior, shelves, side panels with disinfectant. Rinse everything well with sterile water.		Between Experiments. More frequent decontamination may be required, depending on use and environmental conditions.			
13	Verify and document all calibrations, at minimum.		✓			
10	Inspect and clean the humidity generator, at minimum.*		Depending upon the quality of water used in the humidification system, it may be necessary to clean more frequently.			
5	Clean drip pan and drain lines.		✓			
9	Clean refrigeration system condenser.*		✓			
8	Verify defrost cycle for below 10°C operation.		✓			
--	Change filters (under normal conditions).		✓			
--	Replace filter elements on the dryer, if applicable. †		✓			
--	Rebuild solenoid valves on the dryer, if applicable. †			✓		
--	Replace/repack the desiccant towers on the dryer, if applicable.				✓	
--	Replace the check valve and o-rings on the dryer, if applicable.					✓

*Qualified service personnel only ~ Regular monitoring routines of the various levels in your unit is encouraged.

† Refer to Puregas Dryer manual included in shipping box.



Maintenance is to be performed by trained personnel only.

Returns for Repair

Prior to returning any materials, please contact our Customer Service Department for a "Return Materials Authorization" number (RMA).

Material returned without an RMA number will be refused.

Disposal



Warning Contamination Hazard

The environmental chamber may have been used for treating and processing infectious substances, which may have caused contamination of the environmental chamber and its components.

Prior to disposal, it is therefore mandatory that all refrigerated environmental chamber components be properly decontaminated.

Clean the environmental chamber components thoroughly, then disinfect or decontaminate them (depending on application).

Fill in and attach a declaration of decontamination with details on decontamination activities performed to the items that are to be disposed of.

Specifications

Parameter	Unit	Models	
		3907	3948
Chamber volume	L / cu ft	311 / 11	821 / 29
Chamber temperature range	°C (°F)	0 - 60 (32 - 140)	
Chamber humidity range	% RH	above ambient to 95	

Unit dimensions	Unit	Models	
		3907	3948
Internal dimensions W x H x D	mm/in	787 x 609 x 686 / 31.00 x 24.00 x 27.00	787 x 1524 x 686 / 31.00 x 60.00 x 27.00
External dimensions (without feet / casters) W x H x D*	mm/in	965 x 1308 x 813 / 38.00 x 51.50 x 32.00	965 x 2248 x 813 / 38.00 x 88.50 x 32.00
Footprint	m ² / ft ²	0,785 / 8.45	
Number of Shelves: standard / maximum		3 / 11	6 / 19
Number of shelf positions		11	19
Shelf material		Solid stainless steel reinforced	
Shelf size (W x D)	mm/in	778 x 656 / 30.62 x 25.81	
Shelf surface area	m ² / ft ²	0,5 / 5.4	
Max. shelves surface area per chamber	m ² / ft ²	5.5 / 59.4	9.5 / 102.6
Loading capacity per shelf, slide in / out Loading capacity per shelf, stationary	kg/lbs	15.9 / 35 22.7 / 50	
Loading capacity of unit	kg/lbs	68 / 150	136 / 300
Weight of unit without accessories	kg/lbs	261 / 575	347 / 765
Weight of unit without accessories incl pack- aging	kg/lbs	325 / 715	426 / 940
External dimensions incl. packaging W x D x H	mm/in	--	1150 x 1245 x 2620/ 45 x 49 x 103
Access ports with stopper		1x access port at the left side 2x stopper each at inside & outside	
Access port diameter	mm/in	54 / 2.13	

		Models		
Temperature Performance without Humidity Control (at ambient temperature 22°C +/-3°C)	Unit		3907	3948
Heat up / cool down time (work space unoccupied), from ambient temperature of 22°C (72 °F) to (according to DIN12880) typical value / max. value	min	0°C (32°F)	65 / 75	110 / 115
		37°C (99°F)	25 / 30	55 / 60
		60°C (140°F)	50 / 60	115 / 125
Recovery time (work space unoccupied), (door opening 30 sec, according to DIN12880) typical value / max. value	min	0°C (32°F)	10 / 12	6 / 8
		37°C (99°F)	10 / 12	3 / 5
		60°C (140°F)	12 / 14	10 / 12
Temperature stability, temporal mid of work space according to DIN12880 at 20°C to 37°C (68°F to 99°F)	°C		≤ ± 0.1	≤ ± 0.1
Temperature uniformity between 25°C to 37°C (77°F to 104°F), spatial according to DIN12880 at typical value / max. value			≤ ±0.3 / ± 0.4	

		Models		
Temperature Performance with Humidity Control (at ambient temperature 22°C +/-3°C)	Unit		3907	3948
Heat up / cool down time (work space unoccupied), from ambient temperature of 22°C (72 °F) to (according to DIN12880), typical value / max. value	min	5°C (41°F) / 80% RH	35 / 40	65 / 70
		30°C (86°F) / 75% RH	15 / 20	20 / 25
		60°C (140°F) / 75%	47 / 52	80 / 85
Recovery time (work space unoccupied), (door opening 30 sec, according to DIN12880), typical value / max. value	min	5°C (41°F) / 80% RH	7 / 9	6 / 8
		30°C (86°F) / 75% RH	5 / 7	2 / 4
		60°C (140°F) / 75%	10 / 13	10 / 13
Temperature & humidity stability, temporal mid of work space according to DIN12880 at 20 °C to 37 °C (68 °F, 99 °F)	°C / % RH		≤ ± 0.1 ≤ ± 5	≤ ± 0.1 ≤ ± 5
Temperature uniformity between 25°C to 37°C, spatial according to DIN12880 at typical value / max. value	°C		≤ ±0.3 / ± 0.4	≤ ±0.3 / ± 0.4
Calibrated Climate Conditions / Temperature Conditions (measuring point is chamber center)	°C (°F) / % RH		40 (104) / 75	

		Models		
Water performance data for humidity system	Unit	3907	3948	
Water supply		Carboy or water system		
Water specification	min	Demineralized water Resistance = 0.5 - 1 MΩ cm		
Input water pressure		gravity to 40 psi (2,76 bar)		
Water consumption for humidity system (without water recirculator system) Measured at ambient temperature of 22°C / 72°F typical value / max. value	Liter per day	25°C (77°F) / 60% RH	ca. 4.0	ca. 5.0
		30°C (86°F) / 75% RH	ca. 11.0	ca. 10.0
		40°C (104°F) / 75% RH	ca. 1.0	ca. 1.5

		Models		
Electrical Data	Unit	3907	3948	
Power line voltage (+/-10%)	V	230	230	
Power line frequency	Hz	50/60	50/60	
Power rating with all options Measured at ambient temperature of 32°C / 82°F	W	3450	3450	
Max current consumption with all options Measured at ambient temperature of 32°C / 82°F	A	15.0	15.0	
Power Cord / Plug		230V: CEE 7/7	230V: CEE 7/7	
Energy consumption (without humidity control) Measured at ambient temperature of 22°C / 72°F typical value / max. value	kWh per day	0°C (32°F)	ca. 18.5	ca. 20.5
		37°C (99°F)	ca. 17.0	ca. 18.0
		60°C (140°F)	ca. 19.0	ca. 21.0
Energy consumption (with humidity control) Measured at ambient temperature of 22°C / 72°F typical value / max. value	kWh per day	5°C (41°F) / 80% RH	ca. 24.5	ca. 25.5
		30°C (86°F) / 75% RH	ca. 32.5	ca. 34.5
		60°C (140°F) / 75%	ca. 23.0	ca. 24.0
Earthing system (e.g. 1/N/PE)		1/N/PE AC	1/N/PE AC	
IP protection system		IP 20		
Protection class		I (PE-connected)		
Overvoltage category according to IEC 60364-4-443		II		

Ambient conditions	Unit	Models	
		3907	3948
Ambient Temperature Range	°C (°F)	16 - 32 (61 - 90)	
Max. rel. humidity in service at or below 32°C, non condensing	% r.F.	55	
Storage temperature range	°C (°F)	20 - 60 (68 - 140)	
Max. humidity in storage, non condensing	% r.F.	90	
Post-transport acclimation time	h	3	
Noise level (measuring point: device-distance of the front side 1,0m, height=1,6m)	dB(A)	≤ 48	≤ 50
Heat load to the environment	W / BTU hour	1750 / 6000	1750 / 6000

Site conditions	Unit	Models	
		3907	3948
Maximum altitude above sea level	m/y NN	2000/2187	
Minimum side clearance	mm/in	150 / 5.9	150 / 5.9
Minimum front clearance	mm/in	1100 / 43.3	1100 / 43.3
Minimum back wall clearance	mm/in	250 / 9.8	250 / 9.8
Minimum top clearance	mm/in	250 / 9.8	250 / 9.8

Continuing research and improvements may result in specification changes at any time. Performance plus or minus the least significant digit unless otherwise specified.

¹ Installation category (overvoltage category) defines the level of transient overvoltage which the instrument is designed to withstand safely. It depends on the nature of the electricity supply and its overvoltage protection means. For example, in CAT II which is the category used for instruments in installations supplied from a supply comparable to public mains such as hospital and research laboratories and most industrial laboratories, expected transient overvoltage is 2500V for a 230V supply.

² Pollution degree describes the amount of conductive pollution present in operating environment. Pollution degree 2 assumes that normally only non-conductive pollution such as dust occurs with the exception of occasional conductivity caused by condensation.

Service



Service must be performed by qualified service personnel only!



De-energize all potential sources of energy to this unit and lockout/tagout their controls.

Remove Software Lockout

1. Press the Advance and Infinity keys at the same time and hold them for about six seconds. The word “Fcty” (factory) will appear in the bottom display. If numbers in the bottom display begin to scroll up or down, the keys have not been pressed simultaneously. Try again.

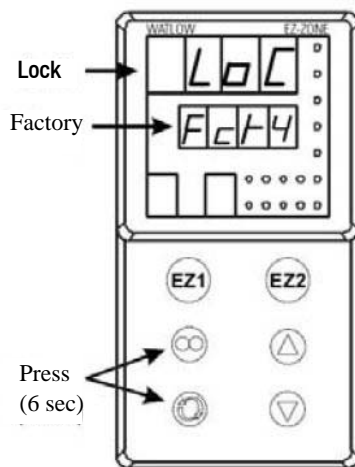

Figure 13-1 Displays

2. Press the Up Arrow until “LoC” (lock) appears in the upper display. The word “Fcty” will remain in the lower display (Figure 13-1).
3. Press the Advance key to scroll through the menus as follows:

Lower display	Upper display	Keystrokes
LoC.o	1	Change to 3 = unlocked
LoC.P	1	No changes required
PAS.E	1	No changes required

Lower display	Upper display	Keystrokes
rLoC	1	Change to 5 = unlocked
SLoC	1	Change to 5 = unlocked

To turn the software lockout back On:

1. Set lock values back to previous setting. See “Remove Software Lockout” above.

Controller Configuration

The Watlow PM Temperature and Humidity Controllers have been configured at the factory. Copies of the Watlow Configuration records are included at the end of this section.



Do not re-configure the controller without first consulting the Technical Services department.

Offset Calibration (Temp/Humidity)

NOTE

Recalibration of setpoint is recommended when different climate classes are used for the applications with and without light function.

It may be necessary to calibrate the temperature or humidity controllers to match an independent temperature or humidity sensor. To do so, follow the next few steps.

1. Perform the “Remove Software Lockout” procedure in this section.
2. Suspend an independent, calibrated sensor(s) in the center of the interior chamber.
3. Allow approximately 30 minutes for the environmental chamber to stabilize.
4. Press Up and Down Arrow keys simultaneously for 3 seconds. The word “OPeR” appears in the lower display.
5. Press Down Arrow until “Ai” appears in the upper display.
6. Press the Advance key until “i.CA” appears in the lower display. Press Up or Down Arrow key to either add or subtract an offset value. This value is the difference between the actual value shown on the controller, and the reference sensor value.
7. Press the Infinity key until the display reverts to normal operation.
8. Perform the ‘Restore Software Lockout’ procedure in this section.

Set Door Heater Control



High voltage is present behind control panel. Servicing must be performed only by qualified electrical service personnel.

The infinite heater control is located in the left side of the environmental chamber top compartment behind the control panel door. The control varies the amount of door heat from no heat (zero) to full heat (100) as indicated by the dial face. If the knob is turned past zero, a “click” indicates that all power to the door is shut off. If turned past 100, a similar “click” indicates that the heat is set at maximum.

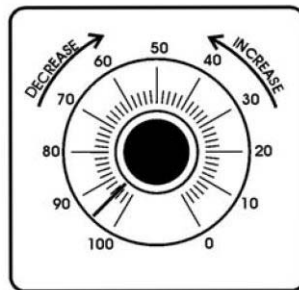

Figure 13-2 Door Heater Control

Initially, the units leave the factory with the dial set at 40. If desired, the amount of heat can later be reduced until moisture appears on the door. However, in fluctuating ambient conditions, it is recommended that a minimum of 40% door heat be used.

Clean/Adjust Steam Generator

Depending upon the quality of water used in the humidification system, it may be necessary to clean the humidity steam generator (P/N 1900190) more frequently than once a year.

Materials Required:

6-foot stepladder
 Flat and Phillips screwdrivers
 11/32 Nutdriver or wrench
 Laboratory disinfectant
 9/16 Open end wrench
 1/2 Open end wrench
 Sponge & cleaning materials



De-energize all potential sources of energy to this unit and lockout/tagout their controls.

1. Remove all contents from the environmental chamber, turn it off, and disconnect from power source.
2. Turn off the valve supplying the sterile distilled water.
3. From the stepladder, remove the eight screws securing the top of the environmental chamber cabinet.
4. When the steam generator has cooled, remove the four thumbscrews and wingnuts (Figure 13-3).

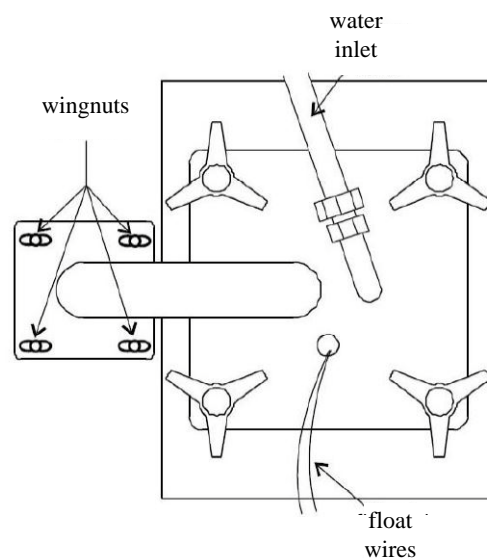

Figure 13-3 Access to Steam Generator

5. Disconnect water inlet from steam generator.



The internal temperature of the steam generator is hot enough to boil water. Make certain, sufficient time is allowed for the unit to completely cool before removing the top.

6. Lift the top off the steam generator and set it aside.
7. Remove the gasket and inspect for damage or excessive wear. Replace if necessary.
8. Loosen the four nuts holding the front cover and remove it. Mark the top of heater location for future reference. Unsnap the two toggle clamps on the heater.
9. Remove the can through the top of the steam generator, taking care not to spill water out of the can. Empty the water. Clean the can with a good quality laboratory detergent and disinfectant. Do not use any type of chloride cleaner. A bristle brush may be needed for stubborn rust and scale. Also clean the inside of the steam tube using a test tube brush. Repeat cleaning with soap and water as necessary.
10. Reassemble in reverse order being sure to align the heater with the reference mark. Center the can with the housing and the gasket with the can opening.

CO₂ Controller Calibration

If it should become necessary, calibrate the CO₂ controller.

Start from the standard operating display (setpoint in bottom display, actual CO₂ reading in the upper display).

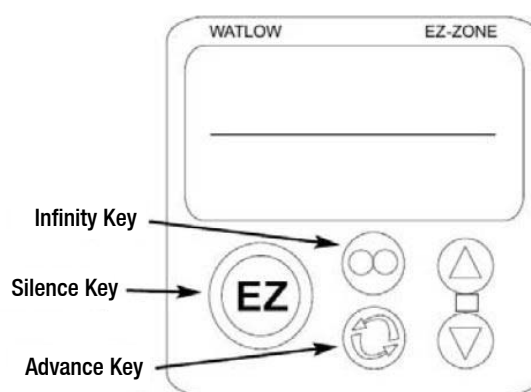

Figure 13-4 Key Locations

Change PID Tuning

The procedure for changing PID tuning values follows.

1. Remove software lockout, if not already performed.
2. From home screen, press and hold the “UP” and “DOWN” arrow keys until the display reads “Oper” in the lower display and “Ai” in the upper display.
3. Press the “DOWN” arrow key until “LOOP” appears in the upper display.
4. Press the “ADVANCE” key until “h.Pd” appears in the lower display.
5. Press the “UP” and/or “DOWN” arrow keys to set the value in the upper display.
6. Press the “ADVANCE” key until “c.Pd” appears in the lower display.
7. Press the “UP” and/or “DOWN” arrow keys to set the value in the upper display.
8. Press the “ADVANCE” key until “ti” appears in the lower display.
9. Press the “UP” and/or “DOWN” arrow keys to set the value in the upper display.
10. Press the “ADVANCE” key until “td” appears in the lower display.
11. Press the “UP” and/or “DOWN” arrow keys to set the value in the upper display.
12. Press the “Infinity” key to return to home screen.
13. Return software lockout to its prior settings.

If the above RH PID parameters do not provide the desired control, the RH controller has an Auto Tune feature that can be initiated. Please follow the Watlow PM Control Auto Tune procedure below.

Watlow PM Control Auto Tune

Prior to performing an RH controller auto tune, heat output 2 in the RH controller should be configured to have a minimum output of 10% due to heater lag in the RH system. Additionally, the cabinet should be running a minimum of 24 hours at the desired temperature control setpoint. This will help ensure the steam generator is at a good operating temperature and the cabinet has reached equilibrium before the auto tune is performed.

See procedure below for setting the minimum output low setting to 10% in the RH controller.

Changing RH Control Output 2 Minimum Output to 10%

1. Remove software lockout.
2. Go into SET UP menu by holding the up and down arrow keys for 6seconds (lower display reads "Set", upper display "Ai").
3. Go to OUTPUT menu by pressing the down arrow key until "OtPt" appears in the upper display.
4. Press the ADVANCE key once (lower display reads "OtPt" and upper display "1").
5. Press the up arrow key once (lower display reads "OtPt", upper display "2").
6. Press the ADVANCE key. The lower display reads "o.Lo". Press the up arrow key until the upper display reads "10".
7. Press the INFINITY key several times until the control returns to normal display.

NOTE

RH control minimum output value should remain at 10% after performing Auto Tune. This provides tighter RH control for most settings.

Auto Tune Procedure

The procedure for changing PID tuning values follows.

1. Remove software lockout, if not already performed.
2. From home screen, press and hold the up and down arrow keys until the display reads "Oper" in the lower display and "Ai" in the upper display.
3. Press the down arrow key until "LOOP" appears in the upper display.
4. Press the ADVANCE key until "A.Tun" appears in the lower display.
5. Press the up arrow key until "YES" appears in the upper display.
6. Press the INFINITY key to return to home screen.

The lower display flashes "TUNE" until Auto Tune has successfully completed.

Configuration Record

TEMPERATURE CONFIGURATION RECORD (WATLOW PM8)								
MODELS:		3907, 3920, 3948						
JOB NUMBER:								
UNT SERIAL NUMBER:								
CONTROL TYPE:		Temperature						
PREPARED BY:		GLS	DATE	24-Sep-2012				
Operations Page: (Press "UP" and "DN" keys for 3 sec.)								
Ai:	Ai 1		Ai 2		§ = AC.Pu in version 10 firmware			
	§(Ain)	---	§(Ain)	---				
	i.Er	*	i.Er	*				
	i.CA	@	i.CA	@				
Lnr:	Lnr 1		Lnr 2					
	Su.A	*	Su.A	*				
	oFSt	@	oFSt	@				
	o.u	*	o.u	*				
Pu:	Pu 1		Pu 2					
	Su.A	*	Su.A	*				
	oFSt	@	oFSt	@				
	o.u	*	o.u	*				
dio:	dio 5		dio 6					
	di.S	oFF	do.6	oFF				
	Ei.S	iACT						
Mon:	C.MA	Auto	C.Pr	*	Pu.A	*		
	h.Pr	*	C.SP	*				
LoopP:	r.En	no	Su.A	no	h.Pb	2.3	td	12
	C.M	Auto	oFSt	*	c.Pb	1.3	db	0.0
	A.tSP	90	o.u	23.9	ti	90	o.SP	0.0
ALM:	ALM 1		ALM 2		ALM 3		ALM 4	
	A.Lo	-20.0	A.Lo	32.0	A.Lo	32.0	A.Lo	32.0
	A.hi	34.0	A.hi	300.0	A.hi	300.0	A.hi	300.0
	¹ (A.St)	*	¹ (A.St)	*	¹ (A.St)	*	¹ (A.St)	*
P.StA:	P.Str	-20.0	A.Lo	32.0	A.Lo	32.0		
	P.Acr	34.0	A.hi	300.0	A.hi	300.0		
(P.AtA group parameters are for Ramp/Soak programming only)								
Setup Page: (Press "UP" and "DN" keys for 6 sec.)								
Ai:	Ai 1				Ai 2			
	SEn	rO.IH	dEC	0.0	SEn	oFF	¹ (i.CA)	@
	rt.L	3	¹ (i.CA)	@	rt.L	0.5	¹ (Ain)	*
	FiL	2.0	¹ (Ain)	*	FiL	oFF	¹ (i.Er)	*
	i.Er	oFF	¹ (i.Er)	*	i.Er	0		
Lnr:	Lnr 1		Lnr 2		(All other parameters at default values)			
	Fn	oFF	Fn	oFF				
Pu:	Pu 1		Pu 2					
	Fn	oFF	Fn	oFF				
	FiL	0.0	FiL	0.0				
dio:	dio 5		dio 6					
	dir	oFF	dir	oFF				
	Fn	0.0	Fn	0.0				

TEMPERATURE CONFIGURATION RECORD (WATLOW PM8)									
MODELS:	3907, 3920, 3948								
JOB NUMBER:									
UNT SERIAL NUMBER:									
CONTROL TYPE:	Temperature								
PREPARED BY:	GLS/HG				DATE	24-Sep-2012/24-Oct-2019			
Operations Page: (Press "UP" and "DN" keys for 3 sec.)									
LoOp:	h.AG	Pid	¹ (db)	0.0	L.dE	no	SP.hi	100.0	
	C.Ag	Pid	i.Er	no	rP	oFF	¹ (o.SP)	*	
	C.Cr	oFF	i.Er	90	L.SP	-20.0	¹ (C.M)	*	
	¹ (h.Pb)	2.3	i.Er	Cr it	h.SP	60.0			
	¹ (c.Pb)	1.3	i.Er	0.0	¹ (C.SP)	*			
	¹ (ti)	90	i.Er	USEr	¹ (id.S)	23.9			
	¹ (td)	12	i.CA	USEr	SP.Lo	-100.0			
otPt:	otPt 1		otPt 2		otPt 3		r.Lo	-20.0	
	Fn	Cool	Fn	hEAt	o.ty	MA	r.hi	80.0	
	o.tb	30.0	o.Ct	Ftb	Fn	rMt	o.CA	@	
	o.Lo	0	o.tb	² 5.0	r.Sr	Ai			
	o.hi	100	o.Lo	0	Fi	1	otPt 4		
			o.hi	² 100	S.Lo	4.00	Fn	ALM	
					S.hi	20.00	Fi	1	
ALM:	ALM 1		ALM 1		ALM 1		ALM 2		
	A.ty	Pr.AL	A.Sd	both	A.Si	oFF	A.ty	oFF	
	Sr.A	Ai	¹ (A.Lo)	-20.0	A.dSP	oFF	ALM 3		
	iS.A	1	¹ (A.hi)	34.0	¹ (A.St)	0	A.ty	oFF	
	A.hy	0.6	A.LA	nLAt	¹ (A.St)	*	ALM 4		
	A.Lg	ALC	A.bL	oFF			A.ty	oFF	
FUn:	FUn 1		FUn 2						
	LEv	high	LEv	high					
	Fn	nonE	Fn	nonE					
	Fi	0	Fi	0					
gLbL:	C_F	C	gSE	oFF	C.LEd	both	d.ti	0	
	AC.LF	60	Si.A	5	ZonE	oFF	Usr.S	nonE	
	r.tyP	ti	Si.b	6	ChAn	oFF	Usr.r	nonE	
	P.tyP	StPt	Pot i	0	d.PrS	1			
CoM:	Ad.S	1	MAP	1	nU.S	yES			
rtC:	hoUr	@	Min	@	doW	@			
Factory Page: (Press "Infinity" and "Advance" keys for 6 sec.)									
LoC:	LoC.o	2	PAS.E	oFF	SLoC	1\$			
	LoC.P	3	rLoC	1 \$					
CUS:	CUS1		CUS2		CUS3		CUS4 thru 20		
	PAR	AC.Pu	PAR	AC.SP	PAR	P.ACr	PAR	nonE	
* Displays current controller value (Display only)									
\$ LOC could be set at 5 until factory testing and calibration is complete									
@ This is a calibration factor and will vary from unit to unit									
¹ Indicates parameters added in version 11.00 control firmware. Not present in ver. 10.00									
² For models 3920 and 3948 with production date later than 15-Sep-2019: o.tb = 0.2 and o.hi = 80									

HUMIDITY CONFIGURATION RECORD (WATLOW PM8)									
MODELS:		3907, 3920, 3948							
JOB NUMBER:									
UNT SERIAL NUMBER:									
CONTROL TYPE:		Humidity							
PREPARED BY:		GLS/HG		DATE	24-Sep-2012/24-Oct-2019				
Operations Page: (Press "UP" and "DN" keys for 3 sec.)									
Ai:	Ain	*	i.Er	*	i.CA	@			
Lnr:	Su.A	*	oFST	@	o.u	*			
Pu:	Su.A	*	oFST	@	o.u	*			
dio::	dio 5		dio 6						
	di.S	oFF	do.S	oFF					
	Ei.S	iACT							
Mon:	C.MA	Auto	C.Pr	*	Pu.A	*			
	h.Pr	*	C.SP	*					
Loop:	C.M	Auto	C.SP	*	c.Pb	3.8 (4)	db	0.0 (0)	
	A.tSP	100	id.S	75.0 (75)	ti	51	o.SP	24.0	
	AUt	no	h.Pb	6.0 (6)	td	8			
ALM:	ALM 1		ALM 2		ALM 3		ALM 4		
	A.Lo	0.0 (0)	A.Lo	32.0	A.Lo	32.0	A.Lo	32.0	
	A.hi	100.0 (100)	A.hi	300.0	A.hi	300.0	A.hi	300.0	
	¹ (A.St)	*	¹ (A.St)	*	¹ (A.St)	*	¹ (A.St)	*	
P.StA:	P.Str (1 thru 40)		Ent1	oFF					
	P.ACr	nonE	Ent2	oFF					
(P.AtA group parameters are for Ramp/Soak programming only)									
Setup Page: (Press "UP" and "DN" keys for 6 sec.)									
Ai:	SEn	voLt	r.Lo	0 (0)	i.Er	oFF	¹ (i.Er)	*	
	Unit	rh	r.hi	100 (100)	dEC	0.5			
	S.Lo	0.00	P.EE	oFF	¹ (i.CA)	@			
	S.hi	5.00	FiL	2.0	¹ (Ain)	*			
Lnr:	Fn	oFF	(All other parameters at default values)						
Pu:	Fn	oFF	FiL	0.0					
dio:	dio 5		dio 6						
	dir	in	dir	otPt					
	LEv	high	Fn	oFF					
	Fn	nonE							
	Fi	0							
Loop:	h.AG	Pid	¹ (db)	1.0	L.dE	no	SP.hi	100.0	
	C.Ag	Pid	t.tUn	no	rP	oFF	¹ (o.SP)	24.0	
	C.Cr	oFF	¹ (A.tSP)	100	L.SP	0.0 (0)	¹ (C.M)	Auto	
	¹ (h.Pb)	6.0 (6)	t.Agr	Cr it	h.SP	100.0 (100)			
	¹ (c.Pb)	3.8 (4)	P.dL	0.0	¹ (C.SP)	*			
	¹ (ti)	51	UFA	0	¹ (id.S)	75.0 (75)			
	¹ (td)	8	FAiL	USEr	SP.Lo	-100.0			
otPt:	otPt 1		otPt 2		otPt 3		r.Lo	0	
	Fn	CooL	Fn	hEAt	o.ty	MA	r.hi	100	
	o.tb	10.0	o.Ct	utb	Fn	rMt	o.CA	@	
	o.Lo	0	o.Lo	0	r.Sr	Ai			
	o.hi	100	o.hi	100	Fi	1	otPt 4		
					S.Lo	4.00	Fn	ALM	
					S.hi	20.00	Fi	1	

HUMIDITY CONFIGURATION RECORD (WATLOW PM8)									
MODELS:	3907, 3920, 3948								
JOB NUMBER:									
UNT SERIAL NUMBER:									
CONTROL TYPE:	Humidity								
PREPARED BY:	GLS			DATE	24-Sep-2012				
Operations Page: (Press "UP" and "DN" keys for 3 sec.)									
ALM:	ALM 1		ALM 1		ALM 1		ALM 2		
	A.ty	Pr.AL	¹ (A.Lo)	0.0 (0)	A.dSP	on	A.ty	oFF	
	Sr.A	Ai	¹ (A.hi)	100.0 (100)	¹ (A.dL)	()	ALM 3		
	A.hy	0.3 (0)	A.LA	nLAt	¹ (A.St)	*	A.ty	oFF	
	A.Lg	ALC	A.bl	oFF			ALM 4		
	A.Sd	both	A.Si	on			A.ty	oFF	
FUn:	FUn 1		FUn 2						
	LEv	high	LEv	high					
	Fn	SiL	Fn	SiL					
	Fi	1	Fi	1					
gLbL:	C_F	C	gSE	oFF	C.LEd	oFF	d.ti	0	
	AC.LF	60	Si.A	5	ZonE	oFF	Usr.S	nonE	
	r.tyP	ti	Si.b	6	ChAn	oFF	Usr.r	nonE	
	P.tyP	StPt	Pot i	0	d.PrS	1			
CoM:	Ad.S	1	MAP	1	nUS	yES			
rtC:	hoUr	@	Min	@	doW	@			
Factory Page: (Press "Infinity" and "Advance" keys for 6 sec.)									
LoC:	LoC.o	2	PAS.E	oFF	SLoC	1\$			
	LoC.P	3	rLoC	1 \$					
CUSr:	CUSr 1		CUSr 2		CUSr 3		CUSr 4		
	PAr	AC.Pu	PAr	AC.SP	PAr	P.AC	PAr	nonE	
* Displays current controller value (Display only)									
\$ LOC could be set at 5 until factory testing and calibration is complete									
@ This is a calibration factor and will vary from unit to unit									
() Parameter in parenthesis are seen in version 11.00 and later firmware controls.									
¹ Indicates parameters added in version 11.00 control firmware. Not present in ver. 10.00									

CO2 CONFIGURATION RECORD (WATLOW PM6)										
MODELS:		3911, 3913 (KIT1900227), 3907, 3948								
JOB NUMBER:										
UNT SERIAL NUMBER:										
CONTROL TYPE:		CO2								
PREPARED BY:		GLS/HG		DATE	17-Jun-2015/24-Oct-2019					
Program Page: See Programming Sheets if required.*										
Operations Page: (Press "UP" and "DN" keys for 3 sec.)										
Ai:	Ain	*	i.Er	*	i.CA	@				
Lnr:	Su.A	*	oFST	@	o.u	*				
Pu:	Su.A	*	oFST	@	o.u	*				
Mon:	C.MA	*	h.Pr	*	C.SP	*	Pu.A	*		
LoopP:	C.M	AUTO	C.SP	*	ti	310	o.SP	0.0		
	A.tSP	90	id.S	5.0	td	10				
	AUt	no	h.Pb	1.5	db	0.0				
ALM:	ALM 1		ALM 2		ALM 3		ALM 4			
	A.Lo	-1.0	A.Lo	32.0	A.Lo	32.0	A.Lo	32.0		
	A.hi	21.0	A.hi	300.0	A.hi	300.0	A.hi	300.0		
	¹ (A.St)	*	¹ (A.St)	*	¹ (A.St)	*	¹ (A.St)	*		
Setup Page: (Press "UP" and "DN" keys for 6 sec.)										
Ai:	SEn	VOLT	r.Lo	0 (0)	i.Er	oFF	¹ (i.Er)	*		
	Unit	Pro	r.hi	20.0	dEC	0.0				
	S.Lo	0.00	P.EE	oFF	¹ (i.CA)	@				
	S.hi	1.00	FiL	2.0	¹ (Ain)	*				
Lnr:	Fn	oFF	(All other parameters at default values)							
Pu:	Fn	oFF	FiL	0.0						
LoopP:	h.AG	Pid	t.tUn	no	rP	oFF	SP.hi	100.0		
	C.Ag	oFF	¹ (A.tSP)	90	L.SP	0.0	¹ (o.SP)	0.0		
	¹ (h.Pb)	1.5	t.Agr	Cr it	h.SP	20.0	¹ (C.M)	AUto		
	¹ (ti)	310	UFA	USEr	¹ (C.SP)	*				
	¹ (td)	10	FAiL	oFF	¹ (id.S)	5.0				
	¹ (db)	0.0	L.dE	no	SP.Lo	-100.0				
otPt:	otPt 1		otPt 2		otPt 3		S.hi	20.00		
	Fn	hEAt	Fn	ALM	o.ty	MA	r.Lo	0.0		
	o.tb	10.0	Fi	1	Fn	rMt	r.hi	20.00		
	o.Lo	0			r.Sr	Ai	o.CA	0.0		
	o.hi	100			Fi	1				
				S.Lo	4.00					
ALM:	ALM 1		ALM 1		ALM 1		ALM 2			
	A.ty	Pr.AL	¹ (A.Lo)	-1.0	A.dSP	on	A.ty	oFF		
	Sr.A	Ai	¹ (A.hi)	21	¹ (A.dL)	0	ALM 3			
	A.hy	0.3	A.LA	nLAt	¹ (A.St)	*	A.ty	oFF		
	A.Lg	ALo	A.bl	oFF				ALM 4		
	A.Sd	both	A.Si	on				A.ty	oFF	
	FUn:	LEv	high	Fn	SiL	Fi	1			
gLbL:	C.F	C	ZonE	oFF	d.ti	0				
	AC.LF	60	ChAn	oFF	Usr.S	nonE				
	C.LEd	oFF	d.PrS	1	Usr.r	nonE				
CoM:	Ad.S	1	MAP	1	nU.S	yES				
Factory Page: (Press "Infinity" and "Advance" keys for 6 sec.)										
LoC:	LoC.o	2	PAS.E	oFF	rLoC	1\$	SLoC	1\$		
CUST:	CUST 1		CUST 2		CUST 3 thru 20					
	PAr	AC.Pu	PAr	AC.SP	PAr	nonE				
* Displays current controller value (Display only)										
\$ LOC could be set at 5 until factory testing and calibration is complete										
@ This is a calibration factor and will vary from unit to unit										

Honeywell Truline Configuration Record

HONEYWELL TRULINE CONFIGURATION RECORD

SHT 1 OF 4

CUSTOMER: _____
 JOB NUMBER: _____
 UNIT SERIAL #: _____
 CONTROL TYPE: _____
 PREPARED BY: _____ DATE: / /
 COMPLETED BY: _____ DATE: / /

GROUP PROMPT	FUNCTION PROMPT	VALUE OR SELECTION	
TUNING1	PROP BD or GAIN		
	RATE MIN		
	RSET MIN or RESET RPM or MAN RSET		
	CYCSEC		
	PROP BD2 or GAIN2		
	RATE2MIN		
	RSET2MIN or RSET2RPM		
	CYC2SEC		
	TUNING2	PROP BD or GAIN	
		RATE MIN	
RSET MIN or RSET PRM or MAN RSET			
CYCSEC			
PROP BD2 or GAIN2			
RATE2MIN			
RSET2MIN or RSET2RPM			
CYC2SEC			
SP RAMP1		SP RAMP	
		TIME MIN	
	FINAL SP		
	SP RATE		
	EU/HR UP		
	EU/HR DN		
SP RAMP2	SP RAMP		
	TIME MIN		
	FINAL SP		
	SP RATE		
	EU/HR UP		
	EU/HR DN		
	SP PROG		

GROUP PROMPT	FUNCTION PROMPT	VALUE OR SELECTION
CHART	CHRTSPD	7 DAY
	HOUR/REV	
	TIME DIV	21
	MINOR DIV	FOUR
	CONTINUE	NO
	CHART NAME	
	HEADER	YES
	REMSW	NONE
	WAKEMIN	
	WAKE HR	
	WAKE DAY	
TIME	MINUTES	(CURRENT)
	HOURS	(CURRENT)
	DAY	(CURRENT)
	MONTH	(CURRENT)
	YEAR	(CURRENT)
	DAY	(CURRENT)
PEN1	PEN1	ENABLE
	PEN1IN	INPUT 1
	CHART1HI	80
	CHART1LO	-20
	PEN1ON	
	PEN1OFF	
	MAJORDIV	10
	MINORDIV	10
PEN2	RNG1TAG	TEMP
	PEN2	ENABLE
	PEN2IN	INPUT 2
	CHART2HI	100
	CHART2LO	0
	PEN2ON	
	PEN2OFF	
PEN3	MAJORDIV	10
	MINORDIV	10
	RING2TAG	% RH
	PEN3	DISABLE
	PEN3IN	
PEN3	CHART3HI	
	CHART3LO	
	PEN3ON	
	PEN3OFF	
	MAJORDIV	
	MINORDIV	
	RING 3 TAG	

HONEYWELL TRULINE CONFIGURATION RECORD

SHT 2 OF 4

GROUP PROMPT	FUNCTION PROMPT	VALUE OR SELECTION
PEN4	PEN4	DISABLE
	PEN4IN	
	CHART4HI	
	CHART4LO	
	PEN4ON	
	PEN4OFF	
	MAJORDIV	
	MINORDIV	
	RNG4TAG	
INPUT1	DECIMAL	XXX.X
	UNITS	DEG C
	ENGUNITS	
	IN1TYPE	100 PT
	XMITTER	
	IN1HI	482.2
	IN1LO	-184.4
	CUTOFF	
	INPTCOMP	
	FILTER1	2
	BURNOUT	UP
INPUT2	DECIMAL	XXXX
	UNITS	EU
	ENGUNITS	RH
	IN2TYPE	0-5 V
	XMITTER	LINEAR
	IN2HI	100
	IN2LO	0
	CUTOFF2	
	INPTCOMP	
	FILTER2	2
	BURNOUT	UP
INPUT3	DECIMAL	
	UNITS	
	ENGUNITS	
	IN3TYPE	
	XMITTER	
	IN3HI	
	IN3LO	
	CUTOFF3	
	INPTCOMP	
	FILTER3	
	BURNOUT	

GROUP PROMPT	FUNCTION PROMPT	VALUE OR SELECTION	
INPUT4	DECIMAL		
	UNITS		
	ENGUNITS		
	IN4TYPE		
	XMITTER		
	IN4HI		
	IN4LO		
	CUTOFF4		
	INPTCOMP		
	FILTER4		
	BURNOUT		
	TOTAL1	(Value)	
		RESETTOT	
TOTAL1			
TOTALEU			
RATE			
SCALER			
RSETABLE			
TOTAL2	(Value)		
	RSETTOT		
	TOTAL2		
	TOTALEU		
	RATE		
	RSETABLE		
CONTROL1	PID SETS		
	SW VALUE		
	SP SOURC		
	RATIO		
	BIAS		
	SP TRACK		
	POWER UP		
	SP HILIM		
	SP LOLIM		
	ACTION		
	OUT HILIM		
	OUT LOLIM		
	DROPOFF		
	DEADBAND		
	OUT HYST		
	FAILSAFE		
	REM SW		
	MAN KEY		
PBarGAIN			
MINorRPM			
CONT1ALG			
OUT1ALG			
4-20 RNG			
SHEDMODE			
SHED SP			

HONEYWELL TRULINE CONFIGURATION RECORD

SHT 3 OF 4

GROUP PROMPT	FUNCTION PROMPT	VALUE OR SELECTION
CONTROL2	PID SETS	
	SW VALUE	
	SP SOURC	
	RATIO	
	BIAS	
	SP TRACK	
	POWER UP	
	SP HILIM	
	SP LOLIM	
	ACTION	
	OUT HILIM	
	OUT LOLIM	
	DROPOFF	
	DEADBAND	
	OUT HYST	
	FAILSAFE	
	REM SW	
	MAN KEY	
	PBorGAIN	
	MINorRPM	
	CONT1ALG	
	OUT1ALG	
	4-20 RNG	
	SHEDMODE	
SHED SP		
OPTIONS	INPUT 1	ENABLE
	INPUT2	ENABLE
	INPUT3	DISABLE
	INPUT4	DISABLE
	CONTROL1	DISABLE
	CONTROL2	DISABLE
	REJFREQ	60 HZ
	HF REJ	ENABLE
	AUX OUT	DISABLE
	4mA VAL	
	20mA VAL	
	RELHUMID	NO
	ATMPRES	
	DEVIATION	NONE
	DEVSETPT	
	SCROLL	NONE
	INP ALG	
	COEFF	
	PV HIGH	
	PV LOW	
	RATIO A	
	BIAS A	
	RATIO B	
	BIAS B	
	RATIO C	
	BIAS C	
	GRANDTOT	
	ComSTATE	DISABLE
	ComADDR	
	SHEDTIME	
	UNITS	

GROUP PROMPT	FUNCTION PROMPT	VALUE OR SELECTION	
ALARMS	A1S1 VAL		
	A1S2 VAL		
	A1S1 TYPE	NONE	
	A1S2 TYPE	NONE	
	A1S1 HL		
	A1S1 EV		
	A1S2 HL		
	A1S2 EV		
	AL1 HYST	0.1	
	A2S1 VAL		
	A2S2 VAL		
	A2S1 TYPE	NONE	
	A2S2 TYPE	NONE	
	A2S1 HL		
	A2S1 EV		
	A2S2 HL		
	A2S2 EV		
	AL2 HYST		
	A3S1 VAL		
	A3S2 VAL		
	A3S1 TYPE		
	A3S2 TYPE		
	A3S1 HL		
	A3S1 EV		
	A3S2 HL		
	A3S2 EV		
	AL3 HYST		
	A4S1 VAL		
	A4S2 VAL		
	A4S1 TYPE		
	A4S2 TYPE		
	A4S1 HL		
	A4S1 EV		
	A4S2 HL		
	A4S2 EV		
	AL4 HYST		
	A5S1 VAL		
	A5S2 VAL		
	A5S1 TYPE		
	A5S2 TYPE		
	A5S1 HL		
	A5S1 EV		
	A5S2 HL		
	A5S2 EV		
	AL5 HYST		
	A6S1 VAL		
	A6S2 VAL		
	A6S1 TYPE		
	A6S2 TYPE		
	A6S1 HL		
	A6S1 EV		
	A6S2 HL		
	A6S2 EV		
	AL6 HYST		

Information

Contact

Postal address USA:
Thermo Fisher Scientific LLC
401 Millcreek Road, Box 649
Marietta, OH 45750

Direct 1-740-373-4763
Toll Free, U.S. and Canada 1-800-438-4851
FAX 1-877-213-8051

Internet	http://thermoscientific.com
Technical Support	service.led.marietta@thermofisher.com
Certified Service Web Page	www.unitylabservices.com

EMEA
Postal Address Germany:
Thermo Electron LED GmbH
Robert-Bosch-Straße 1
D - 63505 Langenselbold

Sales	Toll free 0800 1 536 376 or +49 6184 90 6940
Service	Toll free 0800 1 112110 or +49 6184 90 6940
E-Mail	info.labequipment.de@thermofisher.com

[thermoscientific.com](https://www.thermoscientific.com)

© 2020 Thermo Fisher Scientific Inc. All rights reserved. All trademarks are the property of Thermo Fisher Scientific and its subsidiaries. Specifications, terms and pricing are subject to change. Not all products are available in all countries. Please consult your local sales representative for details.

Thermo Fisher Scientific LLC
401 Millcreek Road, Box 649
Marietta, Ohio 45750

United States

Thermo
SCIENTIFIC
A Thermo Fisher Scientific Brand